



# Type LT (-SR)



## Standard Swivel Joints



with Welding Connection

**with Threaded Connection**

for Loading Arms

Food and Pharmaceuticals

# Know how & consulting directly from manufacturer with decades of experience

That's why you choose... The logo for IGATEC International. It features the word 'IGATEC' in a large, bold, grey sans-serif font. Above the 'TEC' part, the word 'International' is written in a smaller, blue sans-serif font. A horizontal blue line runs through the middle of the 'IGATEC' text, passing under the 'International' text.

- **Radial gaskets**  
Allow a maximum of feasible sealing materials and longer lifetime compared to axial gaskets
- **DUPLEX, SUPERDUPLEX, HASTELLOY, ALUMINIUM...**  
We machine all compatible materials
- **ASME, NACE, Norsok, DIN...**  
We manufacture according to all required guidelines and directives
- **Customized connections**
- **IGATEC Swivel Joints**  
Made of carbon steel (e.g. St52-3, ...) are nitrided to reach maximized hardness of surface and optimized corrosion protection at the same time
- **Certifications**  
TA-Luft  
VdS  
ISO 9001:2008

## Headquarter

**IGATEC GmbH &  
IGATEC International GmbH**  
Siemensstraße 18  
D-67346 Speyer

Phone: +49 (0)6232 91 904-0  
Fax: +49 (0)6232 91 904-990  
eMail: [info@igatec.de](mailto:info@igatec.de)

## Subsidiary

**IGATEC International GmbH**  
Profilstraße 6  
D-58093 Hagen

Phone: +49 (0)2331 36 788-0  
Fax: +49 (0)2331 36 788-11  
eMail: [info@igatec-international.de](mailto:info@igatec-international.de)

# Swivel Joint Type LT

## Dimensions:

Nominal diameter	G1/4" up to G2" [alternatively in NPT]
Working pressure P <sub>max</sub>	100 bar / 1.450 psi *
Working temp. T <sub>min/max</sub>	-55°C up to 250°C / -67°F up to 482°F *
Material	42CrMo4, 1.4571 [other materials on request e.g. Aluminium, Hastelloy, etc.]
Gasket material	NBR, Viton, PTFE, HPU
Ball material	Stainless steel
Connection	Threaded (female, NPT, BSP, etc.)
Style	10, 11, 12
Application	Universal

\* P<sub>max</sub> and T<sub>max</sub> may not occur at the same time

## Technical Features:

Design	Standard
No. of ball races	1
Fluid	Diesel, Ethanol, LPG,...
Type of sealing	Radial
External dust seal	Yes
Secondary seal	No
Body	Two-parts
Connection for leakage control	On request
Without grease nipple	On request (e.g. floating suction systems)
Maximum speed	Depends on gasket material

## Further Advantages:

	Perfect concentric run-out, easy handling
--	---

## Additional Function (on request):

Execution: smooth-running(-SR)	<ul style="list-style-type: none"> <li>• Special gasket</li> <li>• Refined surfaces</li> <li>• Fluid dynamical pressure release</li> </ul>
--------------------------------	--

## Certifications:

	TA-Luft
--	---------

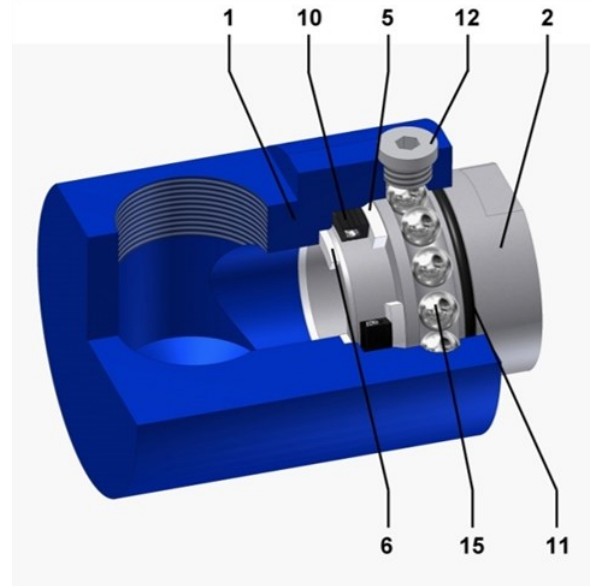

### Pos. Description

1	Outer part
2	Inner part
5	Back up ring
6	Internal wiper
10	Gasket
11	Dust Seal
12	Plug
15	Ball
16	Grease nipple

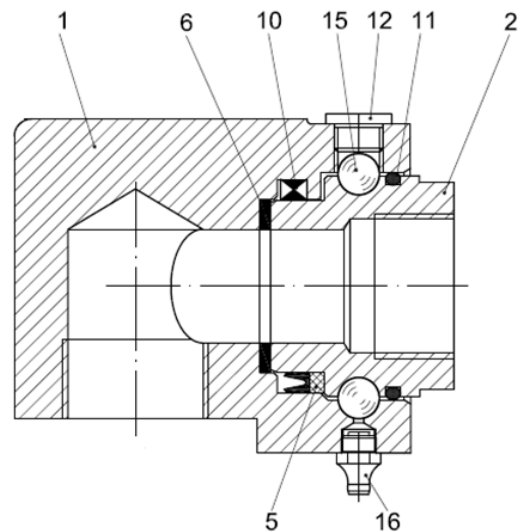

## Type LT

DN	8	10	15	20	25	32	40	50
T1 ["]	1/4"	3/8"	1/2"	3/4"	1"	1 1/4"	1 1/2"	2"
L1 [mm]	78	78	78	78	92	89	110	98
L2 [mm]	98	98	98	98	117	127	127	160
L3 [mm]	118	118	118	118	140	188	199	220
L5 [mm]	78	78	78	78	92	92	92	120
L8 [mm]	78	78	78	78	90	118	129	140
Ø / D	73	73	73	73	87	97	97	117
SW	55	55	55	55	46	60	60	70

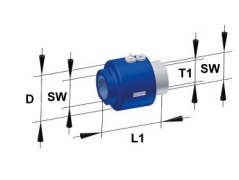
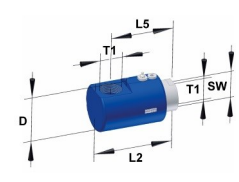
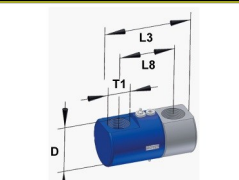
Weight [kg]	Style 10		2.4	2.4	2.4	2.4	2.2	2.9	3.4	4.4
	Style 11		2.8	2.8	2.8	2.8	3.4	5.5	4.6	8.9
	Style 12		3.2	3.2	3.2	3.2	5.4	8.1	8.8	13.7

**Ordering System:**

Type	Connections right / left	Style	Nominal diameter	Material	Working pressure	Miscellaneous	Smooth Running Design
W	S = Female thread (Bush)	10	G1/4" up to G2"	St52-3	up to 1.450 psi  (for applications with higher pressure we offer special swivel joints)	DIN	SR1*
LW		11		1.4571		ANSI	SR2**
T		12		42CrMo4		SAE	
<b>LT</b>		Duplex		...			
V		Hastelloy					
LA		Superduplex					
LCF							
HCR		(other materials on request)					
F							
LF							
FP							
LFP							
<b>LT</b>							

\*SR1 = Special gasket with surface finishing  
 \*\*SR2 = Standard gasket with surface finishing

**Additional Information:**

Media / fluid (gasoline, sulfuric acid, milk, LPG...):  
 Working temperature:  
 Working space situation (dimensions, temperature of environment, etc...):  
 Type of movement (swiveling / angle?, rotation / rpm?...):  
 Side load:  
 Miscellaneous requirements: